

ECONOCADE[®]

TYPE I & TYPE II BARRICADE

Economical,
All Plastic Alternative
to Steel Leg Barricades



- One piece solid construction
- Easy to handle, pack, and transport
- Rust free and impact resistant
- Bottom rail can carry a sand bag
- Two flashing light mounting receptacles
- Available in white, orange, yellow, red, blue, and green
- NCHRP-350 Accepted, Meets MUTCD Standards



Signs or names can be stenciled
directly on the barricade

PLASTICADE[®]

www.plasticade.com

ECONOCADE[®]

TYPE I & TYPE II BARRICADE

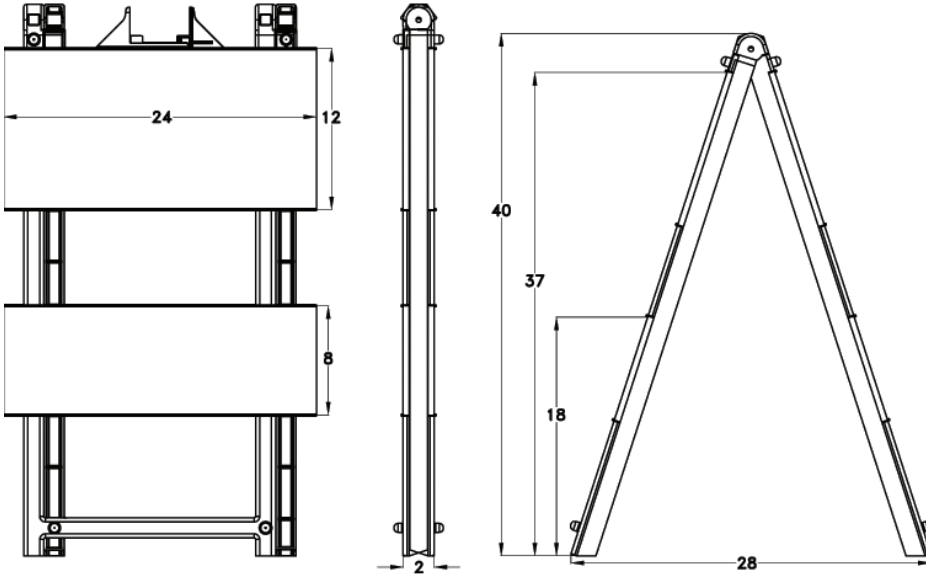

Specs

Composition	High Density Polyethylene
Dimensions	42.6"H x 24.4"W
Colors	White, Yellow, Orange, Red, Blue, Green
Weight	13.2 lbs.
Reflective Sheeting	Available in all grades in white and orange



PLASTICADE[®]

Skokie, IL 60077
 phone (800) 772-0355
 fax (847) 966-8074

www.plasticade.com

MADE IN THE USA